



Shock Absorber Care

Due to the inherent exposure and potential severity of conditions that 4x4 suspension must endure, regularly check for any physical damage that may impair the function of your vehicles suspension.

Clean using soapy water with a sponge or cloth. Avoid prolonged contact with harsh detergents, degreasers and high pressure water spray devices, as this may affect the painted surfaces and decals upon the product.

Some petrochemicals, harsh elements, degreasers, as well as highly acidic, alkaline or salty conditions may deteriorate the rubber, steel and painted surfaces. If you suspect damage due to contact with a damaging substance, ensure the area is thoroughly rinsed with water and please contact your place of purchase for an inspection.

Upon initial use, there may be an oily residue or a small amount of oil originating from the rod seal and surrounding parts, oil can be trapped in the seal assembly and released during transport or initial operation. This is considered normal and should be wiped clean prior to installation or after first use.

Avoid removing the thin film of oil from the piston rod, it is required for smooth seal operation and lubrication. A light oil may be used to rejuvenate the seal if it becomes stripped of its oil coating.

Do not allow mud or debris to accumulate around suspension components, clean and rinse as soon as practical. Dust shields or rubber protective boots are provided by Ironman 4x4 to protect the piston rod from rock and debris damage.

Rubber bushes should not be greased, unless with a specific rubber grease. If wear and tear after use is evident, please contact your place of purchase, as often replacement bushes are available from Ironman 4x4.

Warranty Information

Ironman 4x4 warrants the original buyer, only when purchased new via authorised Ironman 4x4 resellers and distributors, from date of retail sale and cannot be transferred.

Product is warranted against defects in material or workmanship that cause the product to perform below the specified limits set by Ironman 4x4, to the extent that Ironman 4x4 will repair or replace any parts which are found to be defective.

It is at the discretion of Ironman 4x4 if a repair will be made or a replacement issued once the product has been inspected by an Ironman 4x4 representative and deemed to be a genuine warrantable claim.

All warranty claims must be submitted via original purchasing store or chain, unless otherwise arranged. Proof of original purchase must be presented upon request.

Products may be required to be returned to Ironman 4x4 for assessment or repair. Ironman 4x4 is not responsible for postage or removal costs involved, but assistance may be considered at the discretion of Ironman 4x4 in the event of such a claim being verified.

The warranty does NOT apply where, 1) acts of neglect or misuse are evident, 2) product has been modified, 3) vehicles which are modified or not the recommended vehicle of use, 4) used in racing or competition conditions without the prior consent of Ironman 4x4, 5) used beyond the expectations of the original vehicle manufacturer.

Before installation of any product, please ensure you have received the correct parts for your application.

Damage to products through fitment error is not covered under warranty.

Our goods come with statutory guarantees that cannot be excluded under Australian Consumer Law. You are entitled to a replacement or refund for a major failure and for compensation for any other reasonably foreseeable loss or damage contingent on that failure. You are also entitled to have the goods repaired or replaced if they fail to be of acceptable quality even if the failure does not amount to a major failure

Purchase Information



Vehicle: _____

Odometer at install: _____

Product Code: _____

Purchase Date: _____

Purchased From: _____

**For further information please contact us on
+61 (3) 9532 1111 or www.ironman4x4.com**



IRONMAN 4X4 SHOCK ABSORBERS

Installation and Care Guidelines

Thank you for your purchase of Ironman 4x4 shock absorbers. This guide is intended to ensure the product performs safely and provides long term enhancement of your vehicle both on and off road.

Ironman 4x4 shock absorbers will often perform differently compared to original equipment (OEM) shock absorbers. The characteristics of this product are designed by Ironman 4x4 to form part of an integrated Ironman 4x4 suspension system, best performance is achieved in combination with Ironman 4x4 springs and mounting hardware, although not essential.

Ironman 4x4 shock absorbers must only be used for the intended application. Never tamper with or alter the original design of shock absorbers.

Installing Ironman 4x4 Shock Absorbers

In most cases, the Ironman 4x4 shock absorber will replicate the same basic mounting configuration as the original equipment (OEM) shock absorber. Where supplied, **always use new mounting hardware.**

Ensure that all parts received are **correct** and of **acceptable condition** before installation. If any product is suspected to be faulty or incorrect for your application, please contact your place of purchase.

Fitting shock absorbers and struts often requires special tools and expert knowledge. Ironman 4x4 always recommends installation by an experienced mechanic.

Prior Installation Checks

- Prime the shock absorber by fully pumping it upright 2-3 times, ensuring the pressure chambers are fully purged of gas or air bubbles.
- Consult your vehicle manufacturer's workshop manual for model specific details of installation and removal procedures.
- Replace any worn or broken OEM components, do not attempt to repair or re-use damaged suspension components.

Ironman 4x4 Nitro Gas shock absorbers will self-extend due to pressurised nitrogen gas contained within. The rate of gas extension offers little relevance in determining the health or performance of the shock absorber.

Ironman 4x4 Foam Cell shock absorbers will not self-extend like a gas pressurised shock absorber as they do not contain gas pressure - A Foam Cell shock absorber will generally feel firmer to extend than it will to compress.

During Installation

- Do not tighten shock absorber bushes until the vehicle is lowered to the ground. With exception to upper strut mounts, which must be tightened before installing the strut to the vehicle.
- Leave eye ring mounts finger tight ONLY, until the vehicle is lowered to the ground at normal ride height, failure to do this can damage the rubber bond due to twisting resulting in premature bush wear. This is particularly important for load bearing lower strut bush applications.
- Once the vehicle is lowered to the ground, tighten all nuts to specified tensions.
- Check operational clearance around shock absorbers.
- Re-check all fasteners upon completion after lowering to the ground.

Torque Tightening Table

Bolt Diameter (mm)	Torque (ft.lbs)	Torque (Nm)
8	24	32
10	34	45
11	45	61
12	58	79
14	93	126
16	145	197

Installation Tips and Checks

- **Avoid using impact tools** when installing shock absorbers. Self-locking nuts are designed for single use only.
- In most cases, the mounting stems on shock absorbers have a pre-set amount of thread to limit tightening. Where dual applications exist, use diagram 1 as a visual guide for the amount of squeeze / crush on the bush. **DO NOT** use tension chart for stem type mountings (Refer to diagram 1).

Diagram 1

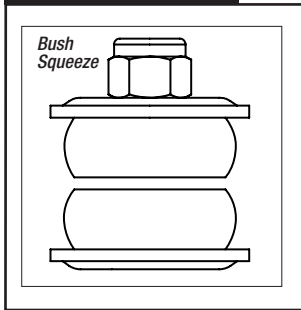

- Always **ensure springs remain fully captive** after installation of longer shock absorbers. When mixing Ironman products with others it's recommended to **check that the range of shock absorber travel matches the available travel in the suspension.**
- **Bump stops must intervene** by at least half their thickness before the shock absorber reaches a fully compressed state.
- Never clamp or use pliers to hold the polished piston rod, do not knock or hit the shaft as this will result in damage to the piston rod and oil seal.

Operating Temperatures

Ironman 4x4 shock absorber ambient operating temperature -30°C to +60°C (-22°F to 140°F).
 12xxx, 24xxx type shock absorber maximum sustained operating temperature 150°C (302°F).
 45xxx, 48xxx type shock absorber maximum sustained operating temperature 185°C (365°F).

Diagram 2

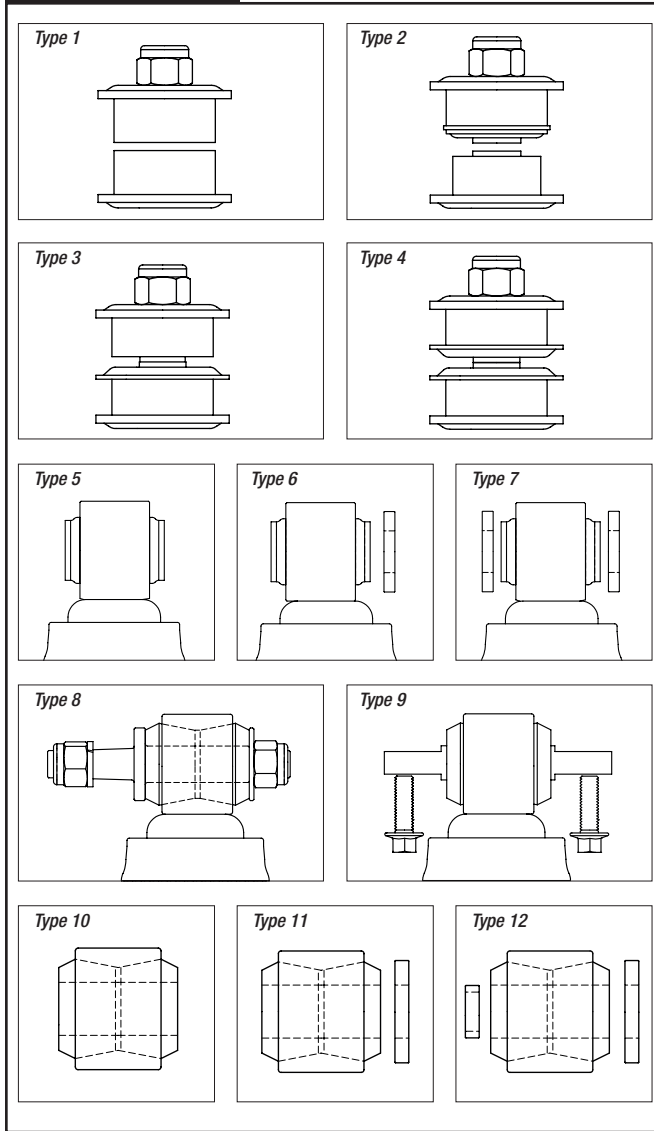

Strut and Spacer Assembly

Some Ironman 4x4 struts differ from OEM counterparts. The spring seat on many Ironman 4x4 struts is fully floating / not fixed to shock absorber body (Refer to diagram 3a). This design allows Ironman 4x4 to offer a range of varied thickness trim packers which can be installed between the spring seat and welded step on shock absorber body.

The installation of spacers affects the ride height and must only be installed after careful consideration and knowledge of ride height situation.

Many independent suspension systems incorporating struts operate at a 1:1.6 or 1:2 motion ratio. For every 1mm of movement (compression or extension) at the strut, equates to 1.6mm to 2mm movement when measured at the wheel. This **MUST** be considered when selecting an optional spacer for installation. For example a 10mm spacer will provide 20mm lift at the wheel in a system subject to 1:2 motion ratio.

Some Ironman 4x4 struts feature a threaded body for ride height adjustment. Use Ironman 4x4, P/N# ISHOCKTOOL001 wrench when making adjustments. It may be necessary to unload the spring tension before making adjustments (Refer to diagram 4b) when setting ride height use the OEM shock absorber as a reference for spring seat height.

Most **independent suspension MUST maintain at least 60mm downward travel from ride height.** Raising ride height too high can damage the suspension components, impair suspension operation and safety.

Consideration must be given to spring relaxation (settling) in relation to measurable ride height loss after new springs have been installed. The loss of ride height associated with spring relaxation can be doubled when measured from the wheel to guard due to motion ratio.

If any doubt exists, please contact your place of purchase, or an authorised Ironman 4x4 outlet.

Safety

- Assembled struts store large amounts of sprung energy. Only mechanics with necessary tools and equipment should attempt to disassemble or assemble a strut. Severe injury or death can result in mishandling of strut assemblies.
- Never loosen or remove strut center top nut until all spring energy is retained within a high quality strut compressor.
- If raising the vehicle from the ground, always ensure the vehicle is adequately supported by secondary stands or blocked to prevent slipping or falling.
- Never heat, cut or drill shock absorbers.

Diagram 3

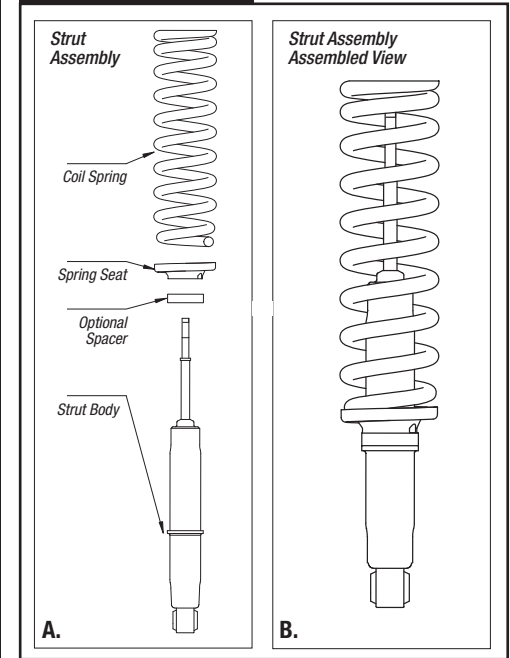

Diagram 4

