

ASFIRTM 4x4













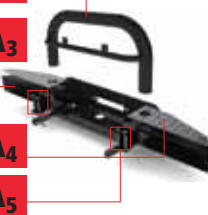

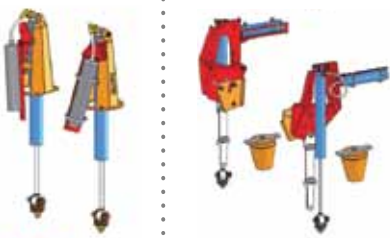





OFF ROAD MASTERS

QUALITY
SKID PLATES
ALUMINUM

Land Rover
Vehicles



Defender

A₁		P/N 538010 TDI/TD5/TD4 90/110/130	Front grill protector	
A₂		P/N 538115 TDI/TD5/TD4 90/110/130	Front bar for ATL bumper	
A₃		P/N 538002 TDI/TD5/TD4 90/110/130	ATL winch bumper	
A₄		P/N 538084 HD Husky TDI/TD5/TD4 90/110/130	Covers for ATL winch bumper	
A₅		P/N 538114 TDI/TD5/TD4 90/110	ATL adapter for Defender with original AC	
B₁			P/N 538075 TDI/TD5/TD4 90/110/130	Steering rod skid plate (Suitable for LH steering only)
B₂		P/N 539114 TDI/TD5/TD4 90/110/130	Front differential protector (Cannot be mounted with B4)	K₁ P/N 538135 Off road suspension kit Front Rear 
B₃		P/N 538113 TDI/TD5/TD4 90/110/130	Front differential protector with welded brackets (Cannot be mounted with B4)	
B₄		P/N 538078 TDI/TD5/TD4 90/110/130	Front axle skid plate (Cannot be mounted with B2 & B3)	
B₅		P/N 539103 until 2001 TDI/TD5 90 Fits Salisbury axle only	Rear differential protector	
B₆		P/N 538074 TD5/TD4 110 P/N 538070 TDI 300 110	Fuel tank skid plate	
B₇		P/N 538073 TD5 90 P/N 538071 TDI 90	Fuel tank skid plate	K₂ P/N 538116 Front bump stop kit 
B₈		P/N 538065 TD4 110	Transmission (Gear) skid plate	
C		P/N 538122 TDI/TD5/TD4 110 P/N 538126 TDI/TD5/TD4 90	Side protectors	K₃ P/N 538134 Front air shock kit 
D		P/N 538079 TDI/TD5/TD4 90/110/130	Steering rod	
E		P/N 538045 TDI/TD5/TD4 90 P/N 538047 TDI 90/110	Detachable tow bar	K₄ P/N 538117 Rear air shock kit 
F		P/N 538099 TDI/TD5/TD4 90/110	Spare wheel carrier (hard top only) (Cannot be mounted on vehicles with central electric locking system)	
H		P/N 538100 TDI/TD5/TD4 110	Side shelf	
I		P/N 538118 TDI/TD5/TD4 90/110	Hi Lift Jack carrier	

*** For More Products Visit Our Website: www.asfir.com ***

Off road kit:

Asfir's off road system was initially developed for military use. The idea was to improve the stability and traversability of vehicles carrying heavy loads and driving on rough off road terrain. The civilian kit was modified for use by the average off roader, seeking extra stability and a better ride.

Asfir's off road suspension system is standardized to fit a vehicle that is equipped with:

- 16 mm front spring - Land Rover original.
- 19.6 mm rear spring - Land Rover original.
- Front axle weight 1100 kg's - 1700 kg's
- Rear axle weight 1100 kg's - 1300 kg's
- Tires - 750/16
- Wheels - Land Rover original.

The kit can be calibrated by Asfir to fit vehicles with different weights, tires, wheels and springs.

Advantages:

- Expands the suspension stroke.
- Extends the vehicle's traversability.
- Provides the vehicle with more flexibility and prevents torsion of the chassis during harsh off road conditions.
- Improves the vehicle's breaking abilities at all speeds.
- Can be ordered to fit any spring that is mounted on the vehicle.
- Maintains the vehicle's original geometry.
- Does not require any changes to be made to the vehicle.
- Utilizes the full stroke of the shock absorber - 10" front shock absorber & 14" rear shock absorber (as opposed to 8" on the original front and rear shock absorber).
- Does not interfere with the vehicle's original top travel (minimal distance of the axle from the body).

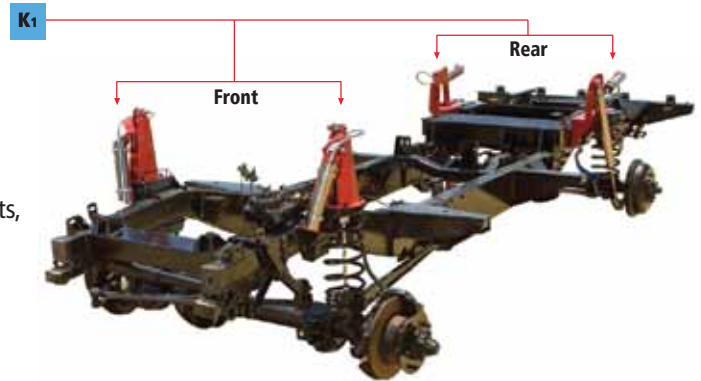

Bump Stop Kit:

The hydraulic bump stop kit was developed to improve the passengers' driving comfort.

When the suspension stroke is in its closed position, the axle reaches the bump stop. The hydraulic bump stop suspends and prevents the passengers from feeling bumps in the driving compartment.

Air shock suspension system

Patent pending #196574

Asfir's air shock suspension system was initially developed for military use. This kit was developed for armored vehicles - i.e. heavy vehicles. The civilian version was modified for use by utility companies (electricity company, water company), foresters, fire brigade etc. - knowing that vehicles used by these organizations, usually carry a heavier load than a standard vehicle.

Advantages:

- Lowers the vehicle's gravity center without interfering with the vehicle's performance.
- Creates a large dynamic force & improves the vehicle's stability
- Maintains vehicle stability and comfort when vehicle is heavily loaded or not loaded.
- Maintains the vehicle's original geometry.

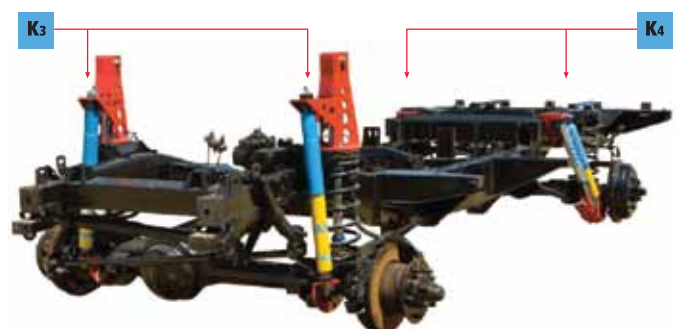

Defender

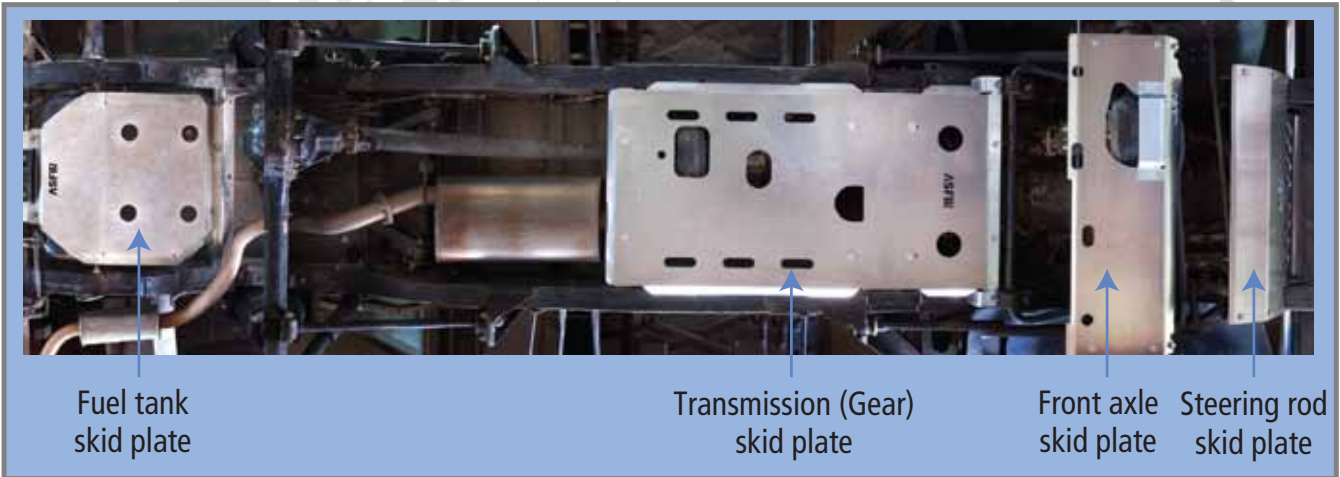

Fuel tank skid plate

Transmission (Gear) skid plate

Front axle skid plate

Steering rod skid plate

Aluminum plating

	P/N	Description	Model
J ₁	538112	Hood cover	TD4 90/110
J ₂	538119	Front wing cover (left+right)	TDI/TD5/TD4 90/110/130
J ₃	538102 538110	Hood cover (can't accommodate a spare wheel) Hood cover (can accommodate a spare wheel)	TDI/TD5 90/110/130 TDI/TD5 90/110/130
J ₄	538121 538127	Rear wing cover (left+right)	TDI/TD5/TD4 110 TDI/TD5/TD4 90

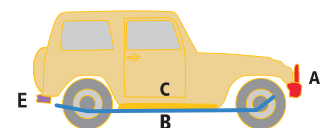
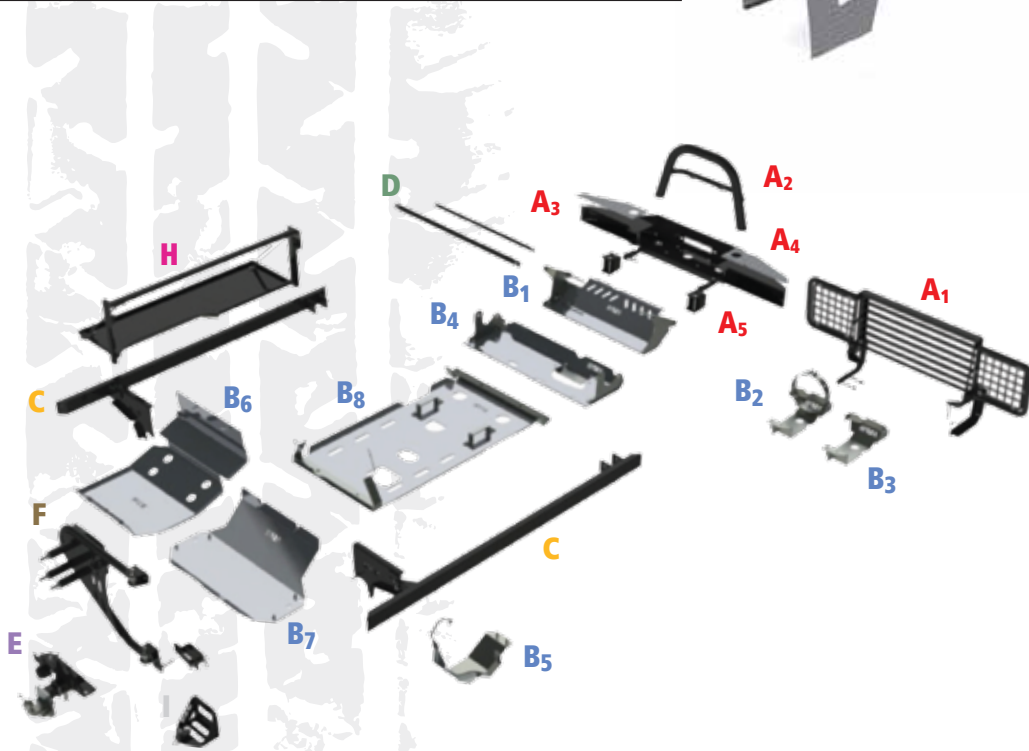
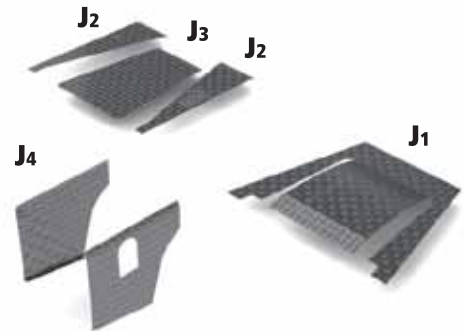

Discovery 3 + 4 & Range Rover Sport

B₁		P/N 539055 Front Skid Plate 05-10 * Fits Range Rover Sport 06-07 Petrol/Gas	 Discovery 3  Discovery 4  Range Rover Sport
B₂		P/N 539061 Transmission (Gear) Skid Plate 05-10 * Fits Range Rover Sport 06-07 Petrol/Gas	
B₃		P/N 539057 Rear Differential Skid Plate LWB 06-10 * Fits Range Rover Sport 06-07 Petrol/Gas	
C		P/N 539053 Side Protectors incl. Side Steps 06-10 * Does not fit Range rover Sport	
D		P/N 539038 Detachable Tow Bar LWB 06-10 * Does not fit Range rover Sport	
E		P/N 539080 Air Tank Skid Plate 05-10 * Fits Range Rover Sport 06-07 Petrol/Gas	

*** For More Products Visit Our Website: www.asfir.com ***







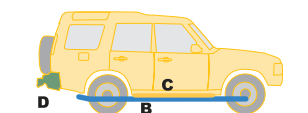









Skid Plates

Side Protectors

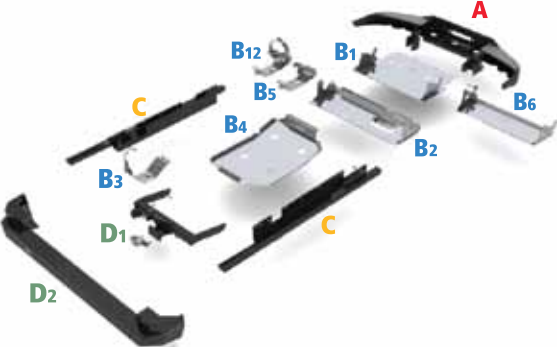





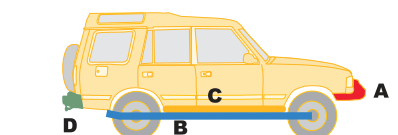









Discovery I

A		P/N 539002	ATL HD winch bumper	
B1		P/N 539113	Steering rod protector for ATL bumper	
B2		P/N 538078	Front axle protector Cannot be mounted with B5, B12	
B3		P/N 539103	Rear differential protector Cannot be mounted with B4	
B4		P/N 539070	Fuel tank skid plate Cannot be mounted with B3	
B5		P/N 538113 w/ welded brackets	Front and rear differential protector Cannot be mounted with B2, B12	
B6		P/N 538132	Steering rod protector for original bumper	
B12		P/N 539114 w/ ring brackets	Differential protector Cannot be mounted with B2, B5	
C		P/N 539052 (5 doors)	Square side protectors	
D1		P/N 539140	Detachable towing device	
D2		P/N 539046	Rear bumper	
E		P/N 538135	Front Off road suspension kit	
*** For More Products Visit Our Website: www.asfir.com ***				

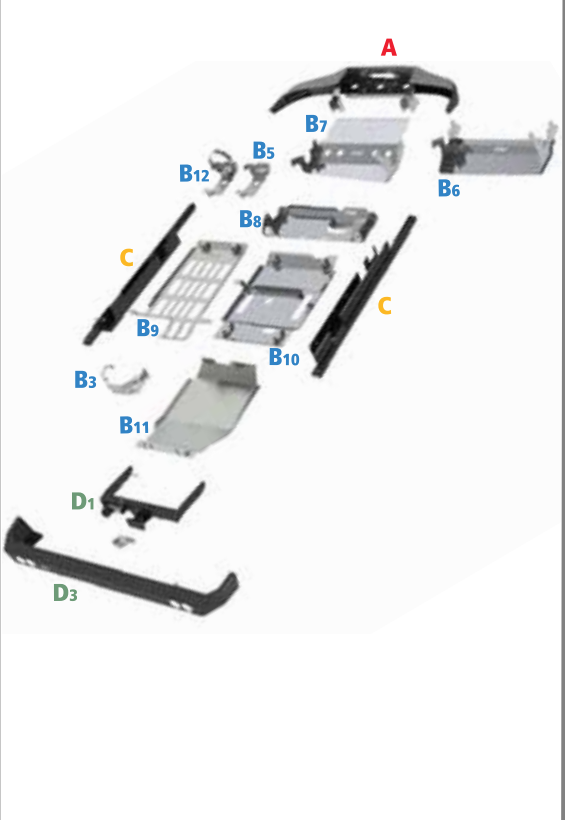

Discovery II

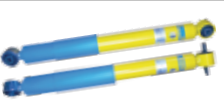
A		P/N 539003 ATL HD winch bumper	
B3		P/N 539103 Rear differential protector Fits Salisbury axle only Cannot be mounted with B11	
B5		P/N 538113 w/ welded brackets Front and rear differential protector Cannot be mounted with B8, B12	
B6		P/N 538104 Steering rod protector for original bumper	
B7		P/N 539116 Steering rod protector for ATL HD bumper	
B8		P/N 538105 Front axle protector Cannot be mounted with B5, B12	
B9		P/N 539060 Transmission (Gear) skid plate (Steel) Cannot be mounted with B10	
B10		P/N 539062 Transmission (Gear) skid plate Cannot be mounted with B9	
B11		P/N 538106 Fuel tank skid plate Cannot be mounted with B3	
B12		P/N 539114 Front differential protector Cannot be mounted with B5, B8	
C		P/N 539052 (5 doors) Square side protectors	
D1		P/N 539143 Detachable towing device	
D3		P/N 539045 Rear bumper	
E		P/N 8800146 Front Shock absorber P/N 8800147 Rear Shock absorber	

*** For More Products Visit Our Website: www.asfir.com ***

Professional Quality Products

Asfir's variety of products is the perfect solution for accessorizing the off-road vehicle.

ATL Winch Bumper

The innovative ATL winch bumper is designed and developed to replace the original bumper.

The bumper covers the winch, but is not attached to it. ATL bumpers are characterized in low weight and in keeping close proximity to the vehicle's original contour lines.

Side Protectors

Protect the lower side of the vehicle and aid recovery with a jack. Designed by Asfir's Research & Development team and manufactured using the most up-to-date technology. The side protectors are made of quality metal and can be combined with aluminum side steps.

Skid Plates

Quality skid plates for off road vehicles have one of the highest design, performance and finish standards in the world.

Asfir offers various skid plates protecting the underbody parts of the vehicle such as front, fuel tank, rear axle, steering rod and gear. The skid plates are made of quality aluminum and are screwed to original holes in the vehicle. Service openings in the skid plates enable servicing the vehicle without dismantling the plates.

Towing Device

A quality detachable towing device mounted to the vehicle's chassis under the original bumper.

4X4 Accessories

Asfir has a wide variety of accessories such as suspension seats, roll bars, front "A" bumpers recovery kits, compressors, Hi Lift jacks, recovery straps, shackles, pulley blocks and ratchets.



ASFIR
4x4

5.2013

QUALITY 4x4 ACCESSORIES

ASFIR LTD

Tel Adashim 19315, **Israel**

Telephone: +972-4-6511400

1-599-599-499*

Fax: +972-4-6527742

E mail: info@asfir.com

www.asfir.com

*(Israel only)



Distributed by :

