



DRIVESHAFT CENTRE BEARING SPACER KIT

Installation Instructions

Part No. 1194K

Ford Ranger / Mazda BT50 10/2011+

Up to 20mm Spacing with 5mm Increments

Allow 20 - 30 Mins Installation time

This kit is intended to reduce vibration as much as possible to achieve a satisfactory result. Vibration may not be eliminated completely.

Always wear personal safety protection ie. Safety glasses and gloves to prevent injury.

1. Operation may be performed on ground, or if raised, ensure the vehicle is supported with suitable jacks / hoist and vehicle stands.

Carefully support driveshaft to prevent injury or damage from a falling shaft.

Perform the following operations to both sides of the bearing.

2. Remove both original nuts from the centre bearing mount and make sure the shaft is adequately supported.
3. Add first spacer plate over stud (See Fig 1).
*Must use the plate with the smaller 10mm hole first.

Add any additional plates as required. It is advisable to start with fewer plates and increase as necessary after test drives (See Fig 2).

All plates must always be used to maintain intended stack height. Any plates not used for spacing must be installed underneath bearing support "Bolt head side" (See Fig A).

4. Install newly supplied bolts with spring washers. Ensure centre bearing is located square and straight to driveshaft and mounts. Using a 21mm socket, tension nuts to 18.5ft/lb / 25Nm (See Fig 3).
DO NOT OVERTIGHTEN
5. Test drive vehicle and assess vibration, if the vibration persists try different configurations using more or less plates.

If all plates are used, there is no further possibility for more.



Fig 1



Fig 2



Fig 3



Fig 4

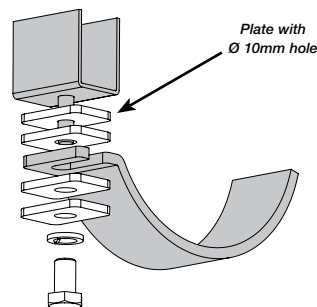

Fig A: 10mm Spacing

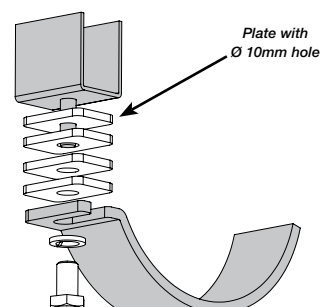

Fig B: Full 20mm Spacing
(All spacers MUST be used)

Warranty will be voided by damage or failure caused by incorrect procedure.

DATE OF ISSUE: 161118